

Lesson 9.5

Areas of Circles

In this lesson you will discover a formula for calculating the area of a circle.

Investigation 9.5



- Step 1** With your compass, make a circle with a radius of approximately three inches. Cut out the circular region.
- Step 2** Fold the circular region in half. Fold it in half a second time. Fold it in half a third time. Fold it in half one last time.
- Step 3** Unfold your circular region and cut it along the folds into 16 wedges.
- Step 4** Arrange the 16 wedges in a row, alternating the tips up and down to form a shape that resembles a parallelogram.

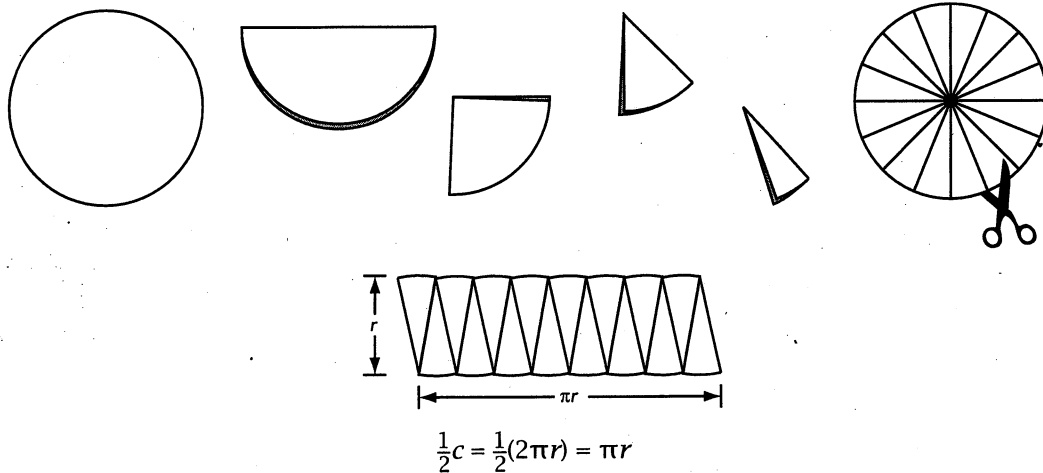

You have just taken apart a circular region and rearranged it into a shape resembling a parallelogram with bumps. If you cut it into more wedges, you can rearrange it to look like a rectangle. No area has been lost or gained in this change from circle to "rectangle," so the area of this new "rectangle" is the same as the area of the original circle. You know how to find the area of a rectangle. If the radius of the original circle is r and the circumference of the original circle is $2\pi r$, then you can determine the base and the height of the "rectangle" and thus its area. State your next conjecture.



C-87 The area of a circle is given by the formula $A = ?$, where A is the area and r is the radius of the circle (*Circle Area Conjecture*).

How do you use this new conjecture? Let's look at a few sample problems.

Example A

The cherry pie shown below has a diameter of 8 inches. What is the area accurate to the nearest tenth of a square inch? Use 3.14 for π .

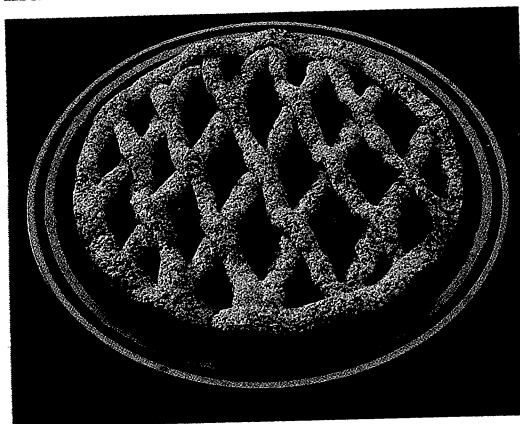

$$\begin{aligned} A &\approx \pi r^2 \\ &\approx (3.14)(4^2) \\ &\approx (3.14)(16) \\ &\approx 50.24 \end{aligned}$$

The area is about 50.2 square inches.

Example B

If the irrigated circular field shown below has an area of $256\pi \text{ m}^2$, what is the length of the rotating sprinkler (the radius of the circle)?



$$\begin{aligned} A &= \pi r^2 \\ 256\pi &= \pi r^2 \\ 256 &= r^2 \\ r &= 16 \end{aligned}$$

The radius is 16 meters.

Take Another Look 9.5



1. Use a geometry computer program to construct the figure shown at right. Measure the area of the circle and the area of the square. Calculate the ratio of these areas. Explain your result.
2. Draw a circle with a radius of 10 cm, then mark off the diameter at 1-cm intervals. Fill the circle with rectangles, as shown. Measure the height of each rectangle to find its area. Sum the areas of the rectangles to find an approximation for the area of the circle. How does this sum compare to the area of the circle? How could you improve on the approximation?

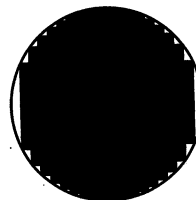
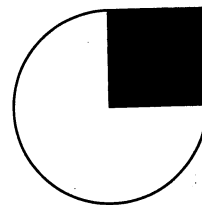

Exercise Set 9.5

Use the Circle Area Conjecture to solve Exercises 1-14. State each answer in terms of π unless asked to use an approximation. For approximations, use the π key on your calculator or use 3.14.

1. If $r = 3$ ", then $A =$?-.
2. If $r = 7$ cm, then $A =$?-.
3. If $r = \frac{1}{2}$ yard, then $A \approx$?-.
4. If $C = 12\pi$ inches, then $A =$?-.
5. If $C = 314$ meters and you use 3.14 for π , then $A \approx$?-.
6. If $A = 9\pi \text{ cm}^2$, then $r =$?-.

7.* If $A = 3\pi$ square inches, then $r = ?$.

9. What is the shaded area between the circle and the rectangle?

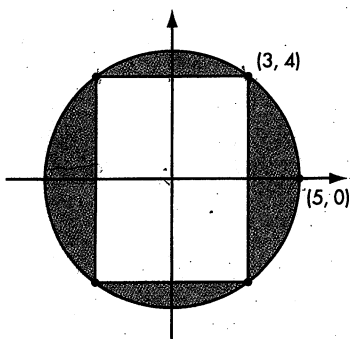

8. If $A = 0.785 \text{ m}^2$, then $r \approx ?$.

10. What is the shaded area between the circle and the triangle?

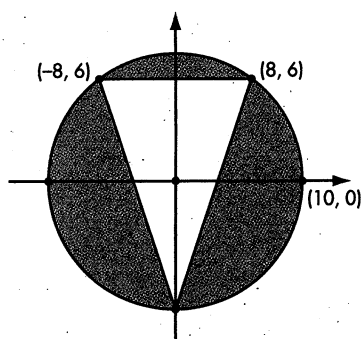

11. Sketch and label a circle with an area of $256\pi \text{ cm}^2$. Be sure to label the length of the radius.
12. A small college TV station can broadcast its programming a radius of 60 km. How many square kilometers of viewing audience does the station have? Express your answer to the nearest square kilometer.
13. A circular rotating sprinkler sprays water over a distance of 5 meters. What is the area of the circular region covered by the sprinkler? Express your answer to the nearest square meter.
14. Juanita's dog, Cecil, has been secured to a post by a chain 7 meters long. Within how many square meters can Cecil play? Express your answer to the nearest square meter.
- 15.* The strength of a bone or a muscle is proportional to its cross-sectional area. If a cross section of one muscle is a circular region with a radius of 3 cm, and a cross section of a second, identical type of muscle is a circular region with a radius of 6 cm, how many times stronger is the second muscle?
16. You've already learned how to find the area of a regular hexagon given the length of its apothem, a , and its perimeter, p . Imagine you kept doubling the number of sides. What would be a good approximation for the area of a 96-sided polygon in terms of r ? Explain your reasoning.

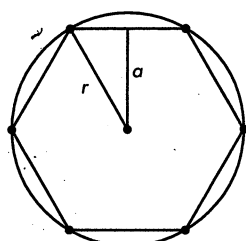

Hexagon

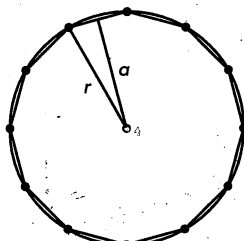

Dodecagon

...

Et cetera

17. **Computer Activity** Construct a parallelogram and a point in its interior. Construct segments from this point to each vertex, forming four triangles. Measure the area of each triangle. Move the point to find a location where all four triangles have equal area. Is there more than one such location? Explain your findings.